

	LONG SHAFT	EXTRA LONG SHAFT
D	512 [20]	636 [25]

LET	REVISIONS	BY	DATE	ECN/CP
A	DRAWING RELEASE	FH	21-NOV-2013	

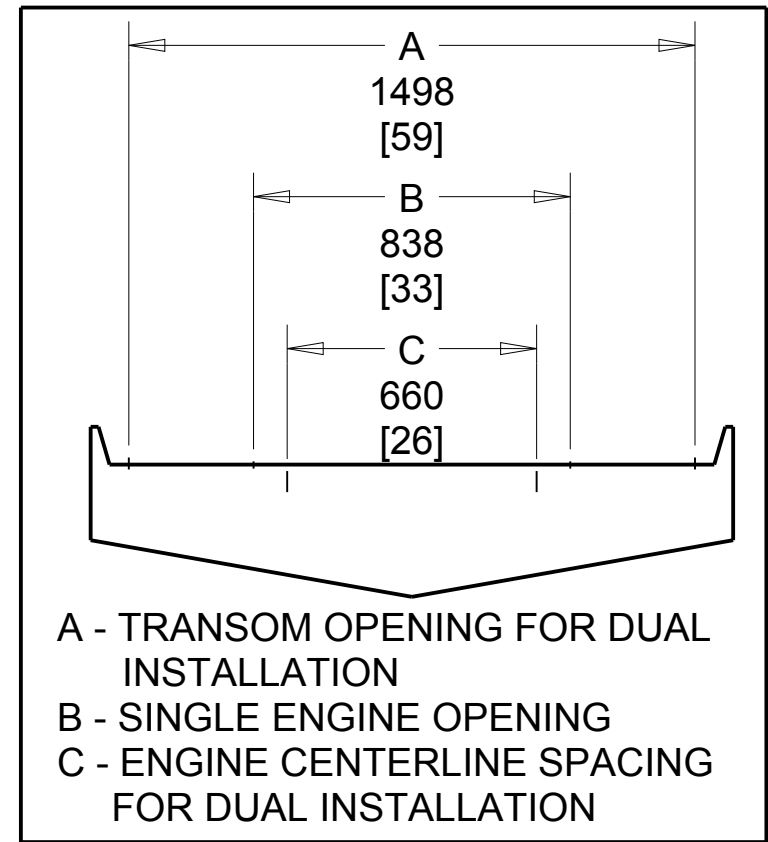
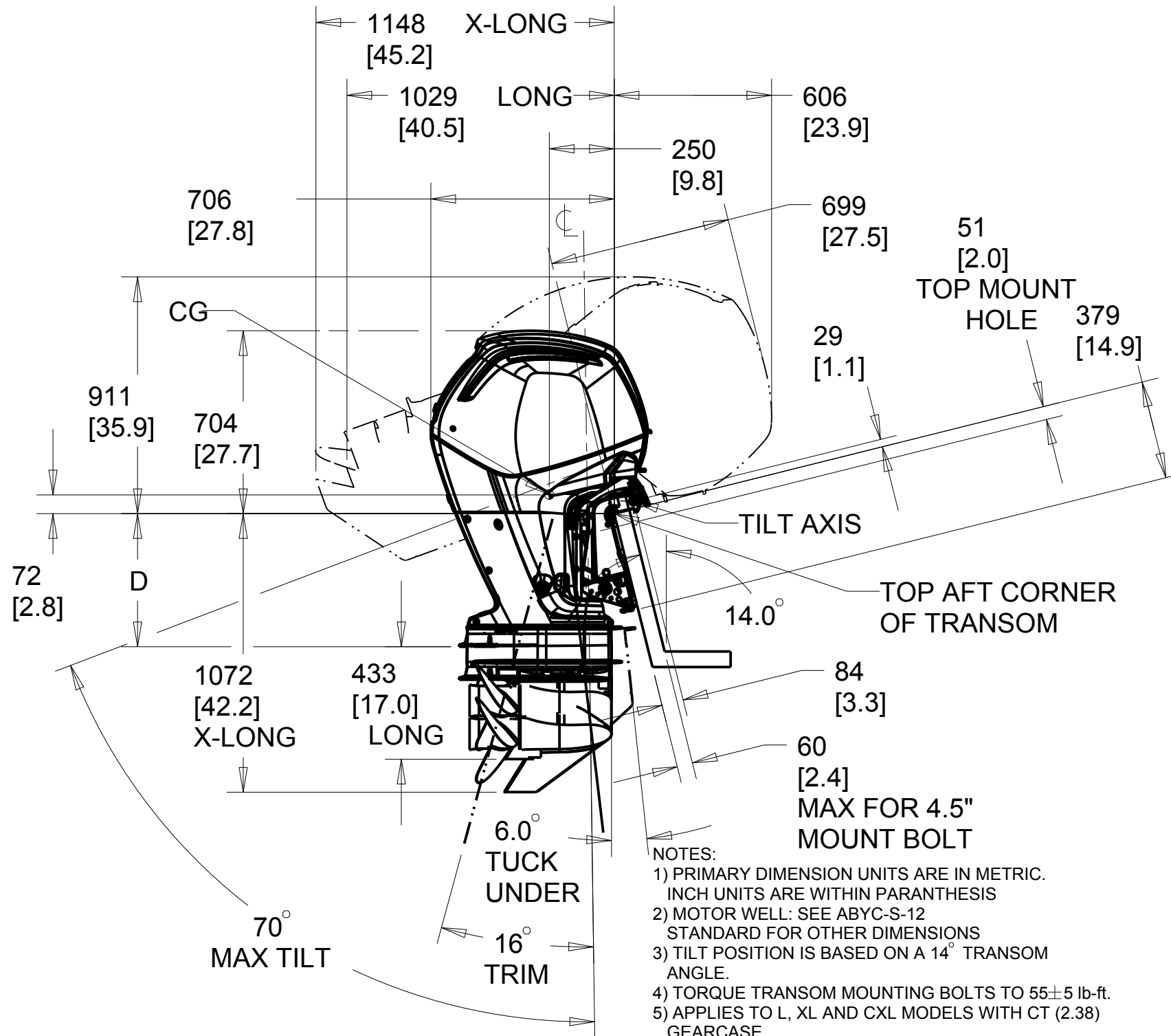
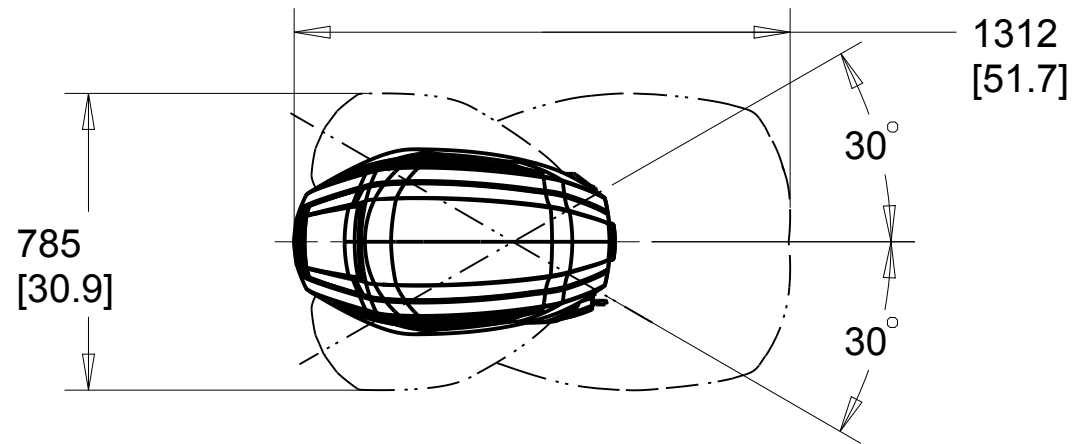
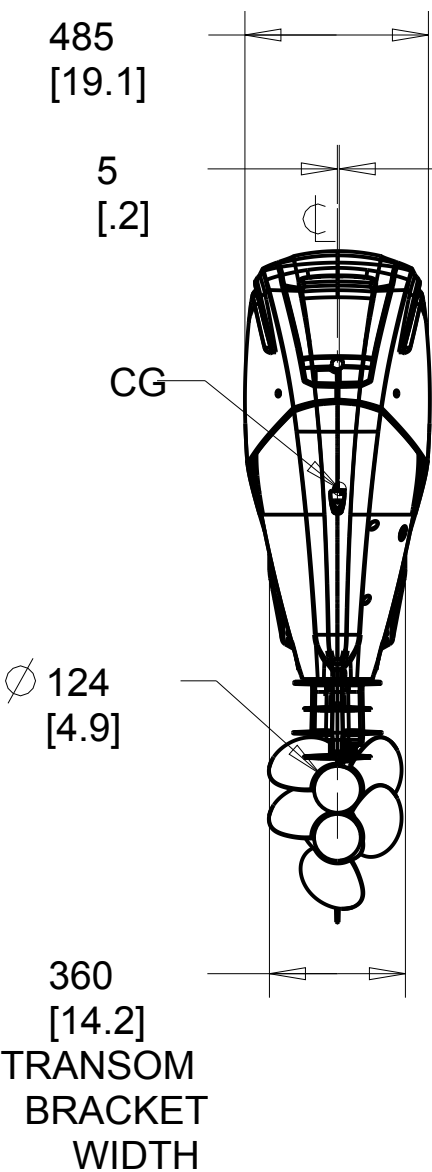

0 KPC'S PER MERC SPEC M-251-G AS NOTED BY <input type="checkbox"/> OR <input type="checkbox"/>		TOTAL KPC'S FOR ALL DRAWING SHEETS	
MATERIAL	XXX	PER MERC SPEC:	
FINISH	XXX	PER MERC SPEC:	
REF SPECS	M-251-G, ASME Y14.5M-1994		
THE INFORMATION CONTAINED IN THIS DOCUMENT IS TO BE TREATED AS TRADE SECRET AND CONFIDENTIAL TO MERCURY MARINE			
INTERPRET DIMENSIONS AND TOLERANCES PER ASME Y14.5M-1994			
THIRD ANGLE PROJ	UNLESS OTHERWISE SPECIFIED		
	METRIC TOLERANCE		ALL DIMENSIONS ARE IN MILLIMETERS DIMENSIONS ARE AFTER PLATING BREAK ALL SHARP EDGES CHAM. TAPPED HOLES 90° X THD DIA MACHINED SURFACES ✓ THREAD LENGTH = FULL THREADS
SCALE: 0.050	LINEAR	±	
DO NOT SCALE	ANGLES	±	
MANUF CAST	MATL ENG		
MANUF MACH / ASSY	PROCUREMENT		
QUALITY	PRODUCT LINE	TITLE	
APPROVED	DATE	115 4S	75 - 115 HP FOURSTROKE INSTALLATION DRAWING 2.38 RATIO GEARCASE
CHECKED	DESIGNED	8M4503648	PART NUMBER
L.TANG	F.HUANG		SHEETS
			1 of 3

- NOTES:
- 1) PRIMARY DIMENSION UNITS ARE IN METRIC. INCH UNITS ARE WITHIN PARANTHESIS
 - 2) MOTOR WELL: SEE ABYC-S-12 STANDARD FOR OTHER DIMENSIONS
 - 3) TILT POSITION IS BASED ON A 14° TRANSOM ANGLE.
 - 4) TORQUE TRANSOM MOUNTING BOLTS TO 55±5 lb-ft.
 - 5) APPLIES TO L, XL AND CXL MODELS WITH CT (2.38) GEARCASE.

- NOTES: 1. STATIC WATERLINE MUST BE BELOW THE IDLE RELIEF OPENING (LOCATED AT REAR OF OUTBOARD) WHEN OUTBOARD IS AT FULL TUCK. INCREASE OUTBOARD MOUNTING HEIGHT OR ADJUST BOAT LOAD IF IDLE RELIEF IS BELOW STATIC WATERLINE AT FULL TUCK.
2. ALL MODELS ARE SHIPPED WITH 12 ft. OF 4 AWG BATTERY CABLES.
MAX. LENGTH IS THE SUM OF BOTH POSITIVE AND NEGATIVE CABLES.
3. FLYWHEEL PULLER/OUTBOARD LIFTING PLATE PART NUMBER IS 91-895343T02.
4. ENGINE PROPPING RPM RANGE:
75-80 = 4500 - 5500
90-115 = 5000 - 6000
5. FUEL LINE ID = 8.0 mm (5/16 IN.)
6. GAS/OIL/LUBRICATION SPECIFICATIONS:
10% ETHANOL MAXIMUM
MINIMUM FUEL OCTANE RATING:
USA AND CANADA = 87 (R+M)/2
OUTSIDE USA AND CANADA +90 RON
ENGINE OIL = NMMA FC-W SAE 10W-30 P/N 8M0078625.
GEARCASE OIL = HIGH PERFORMANCE GEAR LUBE P/N 92-802954A1.
HYDRAULIC STEERING FLUID = HYDRAULIC HELM STEERING FLUID P/N 92-862014Q1.

LET	REVISIONS	BY	DATE	ECN/CP
A	DRAWING RELEASE	FH	21-NOV-2013	



OUTBOARD TRANSOM MOUNTING HARDWARE - SHIPPED WITH OUTBOARD		
PART NO.	PART NAME	DESCRIPTION
10-67755-1	TRANSOM BOLT	1/2 IN. x 20 x 4.50 IN. (2.25 IN. THREAD)
11-826711-17	NYLON INSERT LOCKNUT	1/2 IN. x 20
12-28421	WASHER - INNER	0.516 IN. ID x 1.50 IN. OD
12-54012	WASHER - OUTER	0.53 IN. ID x 0.87 IN. OD

AVAILABLE TRANSOM MOUNTING BOLTS		
PART NO.	PART NAME	DESCRIPTION
10-67755005	TRANSOM BOLT	1/2 IN. x 20 x 2.5 IN. (1.25 IN. THREAD)
10-67755006	TRANSOM BOLT	1/2 IN. x 20 x 3.5 IN. (1.25 IN. THREAD)
10-814259	TRANSOM BOLT	1/2 IN. x 20 x 4.00 IN. (2.25 IN. THREAD)
10-67755-1	TRANSOM BOLT	1/2 IN. x 20 x 4.50 IN. (2.25 IN. THREAD)
10-67755003	TRANSOM BOLT	1/2 IN. x 20 x 5.50 IN. (3.25 IN. THREAD)
10-67755-2	TRANSOM BOLT	1/2 IN. x 20 x 6.50 IN. (2.75 IN. THREAD)
8M0028080	TRANSOM BOLT	1/2 IN. x 20 x 7.50 IN. (2.75 IN. THREAD)

BATTERY CABLES (SEE NOTE 2)	
AWG	MAX LENGTH - METERS/(FEET)
2	12.2 (40)
1	15.2 (50)
1/0	19.6 (64)
2/0	24.4 (80)

STEERING LINK ROD ATTACHING KIT (STANDARD ON GEN.II MODELS)	
PART NO.	KIT APPLICATION
92876A12	FOR STARBOARD CABLE ENTRY

STEERING CYLINDER - HYDRAULIC STEERING (OPTIONAL)	
PART NO.	KIT APPLICATION
898349A01	STEERING CYLINDER - HYDRAULIC

0 KPC'S PER MERC SPEC M-251-G AS NOTED BY <input type="checkbox"/> OR <input checked="" type="checkbox"/>		TOTAL KPC'S FOR ALL DRAWING SHEETS	
MATERIAL	XXX	PER MERC SPEC:	
FINISH	XXX	PER MERC SPEC:	
REF SPECS	M-251-G, ASME Y14.5M-1994		
THE INFORMATION CONTAINED IN THIS DOCUMENT IS TO BE TREATED AS TRADE SECRET AND CONFIDENTIAL TO MERCURY MARINE			
INTERPRET DIMENSIONS AND TOLERANCES PER ASME Y14.5M-1994			
 THIRD ANGLE PROJ	UNLESS OTHERWISE SPECIFIED		
	METRIC TOLERANCE		ALL DIMENSIONS ARE IN MILLIMETERS DIMENSIONS ARE AFTER PLATING BREAK ALL SHARP EDGES CHAM. TAPPED HOLES 90° X THD DIA MACHINED SURFACES <input checked="" type="checkbox"/> THREAD LENGTH = FULL THREADS
SCALE: 0.050	LINEAR	±	
DO NOT SCALE	ANGLES	±	
MANUF CAST	MATL ENG		
MANUF MACH / ASSY	PROCUREMENT		
QUALITY	PRODUCT LINE	TITLE	
APPROVED	DATE	75 - 115 HP FOURSTROKE INSTALLATION DRAWING	
G.FLORES	21-NOV-2013	2.38 RATIO GEARCASE	
CHECKED	DESIGNED	PART NUMBER	SHEETS
L.TANG	F.HUANG	8M4503648	2 OF 3

DUAL OUTBOARD TIE BAR KIT (MECHANICAL)	
PART NO.	KIT APPLICATION
92876A1	FOR OUTBOARD CENTER LINE SPACING OF 56.0 CM (22 IN.) THRU 67.3 CM (26 1/2 IN.)
8149514	EXTENSION COUPLER OR OUTBOARD CENTER LINE SPACING OF 67.3 CM (26 1/2 IN.) THRU 75.5 CM (30 1/2 IN.)



DUAL CABLE - SINGLE OUTBOARD STEERING ATTACHING KIT (MECHANICAL)	
PART NO.	KIT APPLICATION
92876A8	FOR STARBOARD CABLE ENTRY

LET	REVISIONS	BY	DATE	ECN/CP
A	DRAWING RELEASE	FH	21-NOV-2013	

DUAL OUTBOARD TIE BAR APPLICATION - HYDRAULIC STEERING (OPTIONAL)	
PART NO.	KIT APPLICATION
64-892789Q02	FOR STARBOARD CENTER LINE SPACING OF 66.0 CM (26 IN.)
64-892789Q03	FOR STARBOARD CENTER LINE SPACING OF 77.1 CM (28 IN.)
64-892789Q09	FOR STARBOARD CENTER LINE SPACING OF 73.7 CM (29 IN.)
64-892789Q05	FOR STARBOARD CENTER LINE SPACING OF 76.2 CM (30 IN.)
64-892789Q06	FOR STARBOARD CENTER LINE SPACING OF 81.3 CM (32 IN.)
64-892789Q07	FOR STARBOARD CENTER LINE SPACING OF 86.4 CM (34 IN.)
64-892789Q04	FOR STARBOARD CENTER LINE SPACING OF 91.5 CM (36 IN.)

OUTBOARD CENTER LINE SPACING	TIE BAR ASSEMBLED LENGTH	TIE ROD LENGTH	TIE ROD NUMBER
66.0 CM (26 IN.)	29.2 CM (11.5 IN.)	15.9 CM (6.25 IN.)	898465026
71.1 CM (28 IN.)	34.3 CM (13.5 IN.)	21.0 CM (8.25 IN.)	898465028
73.7 CM (29 IN.)	36.8 CM (14.5 IN.)	23.5 CM (9.25 IN.)	898465029
76.2 CM (30 IN.)	39.4 CM (15.5 IN.)	26.0 CM (10.25 IN.)	898465030
81.3 CM (32 IN.)	44.5 CM (17.5 IN.)	31.1 CM (12.25 IN.)	898465032
86.4 CM (34 IN.)	49.5 CM (19.5 IN.)	36.2 CM (14.25 IN.)	898465034
91.5 CM (36 IN.)	54.6 CM (21.5 IN.)	41.3 CM (16.25 IN.)	898465036

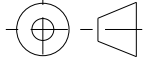
IMPORTANT:
DUAL OUTBOARD INSTALLATIONS UTILIZING THE KIT SUPPLIED TIE BAR MUST HAVE THE OUTBOARD CENTER LINE SPACING MATCHED TO THE TIE BAR SPECIFICATION. TIE BAR INSTALLATION ALLOW FOR A ± 9.5 mm (3/8 IN.) TOLERANCE BETWEEN OUTBOARD CENTER LINE SPACING.

0 KPC'S PER MERC SPEC M-251-G AS NOTED BY <input checked="" type="checkbox"/> OR <input type="checkbox"/>		TOTAL KPC'S FOR ALL DRAWING SHEETS	
MATERIAL	XXX	PER MERC SPEC:	
FINISH	XXX	PER MERC SPEC:	
REF SPECS	M-251-G, ASME Y14.5M-1994		
THE INFORMATION CONTAINED IN THIS DOCUMENT IS TO BE TREATED AS TRADE SECRET AND CONFIDENTIAL TO MERCURY MARINE			
INTERPRET DIMENSIONS AND TOLERANCES PER ASME Y14.5M-1994			
 THIRD ANGLE PROJ	UNLESS OTHERWISE SPECIFIED		
	METRIC		ALL DIMENSIONS ARE IN MILLIMETERS DIMENSIONS ARE AFTER PLATING BREAK ALL SHARP EDGES CHAM. TAPPED HOLES 90° X THD DIA MACHINED SURFACES <input checked="" type="checkbox"/> THREAD LENGTH = FULL THREADS
SCALE: 0.050	LINEAR	\pm	
DO NOT SCALE	ANGLES	\pm	
MANUF CAST	MATL ENG		
MANUF MACH / ASSY	PROCUREMENT		
QUALITY	PRODUCT LINE	TITLE	
	115 4S	75 - 115 HP FOURSTROKE INSTALLATION DRAWING 2.38 RATIO GEARCASE	
APPROVED	DATE	PART NUMBER	SHEETS
G.FLORES	21-NOV-2013	8M4503648	3 OF 3
CHECKED	DESIGNED		
L.TANG	F.HUANG		

